

BILL OF MATERIAL

NO.	NAME OF PART	QTY.	MATERIAL	PART NO.	SPECIFICATION	
1	BODY, VALVE BOTTOM	1	CARBON STEEL OR 316/316LSS	PER ORDER	A105 OR A182 Gr.F316/316L	
2	BODY, VALVE TOP	1	CARBON STEEL OR 316/316LSS	PER ORDER	A105 OR A182 Gr.F316/316L	
3	SEAT, UPSTREAM	1	316/NITRIDE	PER ORDER	UNS 31600	
4	BALL, NITRIDE	1	316/NITRIDE		UNS 31600	
5	SEAL, SEAT	1	316/FLEXICARB		N/A	
6	SEAT, DOWNSTREAM	1	316/NITRIDE		UNS 31600	
7	RETAINER, BALL	1	316SS		A479 OR A240	
8	SPRING, DISC	1	INCONEL 718		B637	
9	GASKET, SPIRAL WOUND	1	316/GRAPHITE		N/A	
10	WASHER, THRUST	1	NITRONIC 50		A276	
11	STEM	1	INCONEL 718		B637	
12	PACKING	3	GRAPHITE		N/A	
13	RING, PACKING	1	NITRONIC 60		A276	
14	RING, SNAP	1	INCONEL 750		B637	
15	CHECK, BALL	1	316SS		A479	
16	FOLLOWER, GLAND	1	STAINLESS STEEL		17-4	
17	STUD, GLAND	4	316SS		A193 Gr.B8M	
18	WASHER, SPRING	8	301SS		UNS 30100	
19	NUT, GLAND	4	316SS		A194 Gr.8M	
20	PIN, SPRING (NOT SHOWN)	1	STAINLESS STEEL		18-8	
21	GLAND, INLET	1	LTCS OR 316/316LSS		PER ORDER	A350 Gr.LF2 OR A479
22	NUT, COMPRESSION	1	LTCS OR 316/316LSS		PER ORDER	A350 Gr.LF2 OR A276
23	PLATE, LOCK	1	316SS	V22123	A479 OR A240	
24	SCREW, PAN HEAD	4	316SS	X171030	A193 Gr.B8M	
25	BUSHING, STEM	1	316/316LSS	V22122	A276 OR A479	
26	ASSEMBLY, HANDLE	1	316/316LSS	S25032	A276	
27	WASHER	1	STAINLESS STEEL	X174093	400 SERIES	
28	NUT, ACORN	1	316SS	X173001 T	A194 Gr.8M	
29	GRIP, HANDLE	1	VINYL	V22080	N/A	
30	TAG, RATING	1	316/316LSS	V22079	A240	
31	SCREW, DRIVE	4	STAINLESS STEEL	P1654 P	18-8	
32	TAILPIECE, UNION GAGE CONN.	1	LTCS OR 316/316LSS	PER ORDER	A350 Gr.LF2 OR A276	
33	NUT, UNION TAILPIECE	1	LTCS OR 316/316LSS	PER ORDER	A350 Gr.LF2 OR A276	
34	GASKET, UNION	2	304/GRAPHITE	V9864 1	N/A	
35	TAILPIECE, UNION TANK CONN.	1	LTCS OR 316/316LSS	PER ORDER	A350 Gr.LF2 OR A276	
36	NUT, UNION TAILPIECE	1	LTCS OR 316/316LSS	PER ORDER	A350 Gr.LF2 OR A276	

1/2" MNPT (OR MSW)	1/2" FNPT (OR FSW)	1/2" MNPT SPH. (OR MSW)	1/2" FNPT SPH. (OR FSW)	3/4" MNPT	3/4" MSW	3/4" FNPT	3/4" MNPT SPH. (OR MSW)	1" MNPT (OR MSW)
7.312 [186]	6.437 [163]	7.937 [202]	7.062 [179]	7.312 [186]	8.125 [206]	6.437 [163]	7.937 [202]	7.750 [197]

1/2" MNPT (OR MSW)	1/2" FNPT (OR FSW)	1/2" MNPT SPH. (OR MSW)	1/2" FNPT SPH. (OR FSW)	3/4" MNPT	3/4" MSW	3/4" FNPT	3/4" MNPT SPH. (OR MSW)	1" MNPT (OR MSW)
4.063 [103]	3.188 [81]	4.688 [119]	3.813 [97]	4.063 [103]	4.063 [103]	3.188 [81]	4.688 [119]	4.500 [114]

1/2"FNPT, 3/4"FNPT, FSW

1/2" OR 3/4"FNPT

- NOTES:
- DIMENSIONS IN INCHES W/ mm EQUIVALENTS IN BRACKETS
 - TOP AND BOTTOM VALVES SAME. (I.E., MIRROR IMAGES) (BOTTOM VALVE SHOWN)
 - VALVE RATING - CARBON STEEL:
2220 PSI @ 100°F, 255 PSI @ 1000°F (MAX)
(156 KG/CM² @ 38°C, 18 KG/CM² @ 538°C)
 - VALVE RATING - 316SS:
2160 PSI @ 100°F, 555 PSI @ 1200°F (MAX)
(152 KG/CM² @ 38°C, 39 KG/CM² @ 649°C)
 - SEE TABLES FOR AVAILABLE STANDARD CONNECTIONS
 - REFER TO THE FOLLOWING (FOR):
 - CATALOG BULLETIN J100.56 (ADDITIONAL INFORMATION)
 - IOM BULLETIN J500.56 (INSTRUCTIONS)
 - CONSULT FACTORY FOR ALTERNATE MATERIALS AND CONNECTION OPTIONS.
 - ASSEMBLY WEIGHT APPROXIMATELY 12.5 LBS

PART NO.	DESCRIPTION	SUPPLIED
G294	STEM PACKING	SET CONTAINING THREE PACKING RINGS
S25189	REBUILD KIT	(1) OF EACH: UPSTREAM SEAT, SEAT SEAL, NITRIDE BALL, BALL CHECK, BALL RETAINER, SNAP RING, DOWNSTREAM SEAT, DISC SPRING, INLET GLAND SPIRAL WOUND GASKET, STEM THRUST WASHER, STEM PACKING, SPRING PIN
V9864 1	UNION GASKET	ONE GASKET

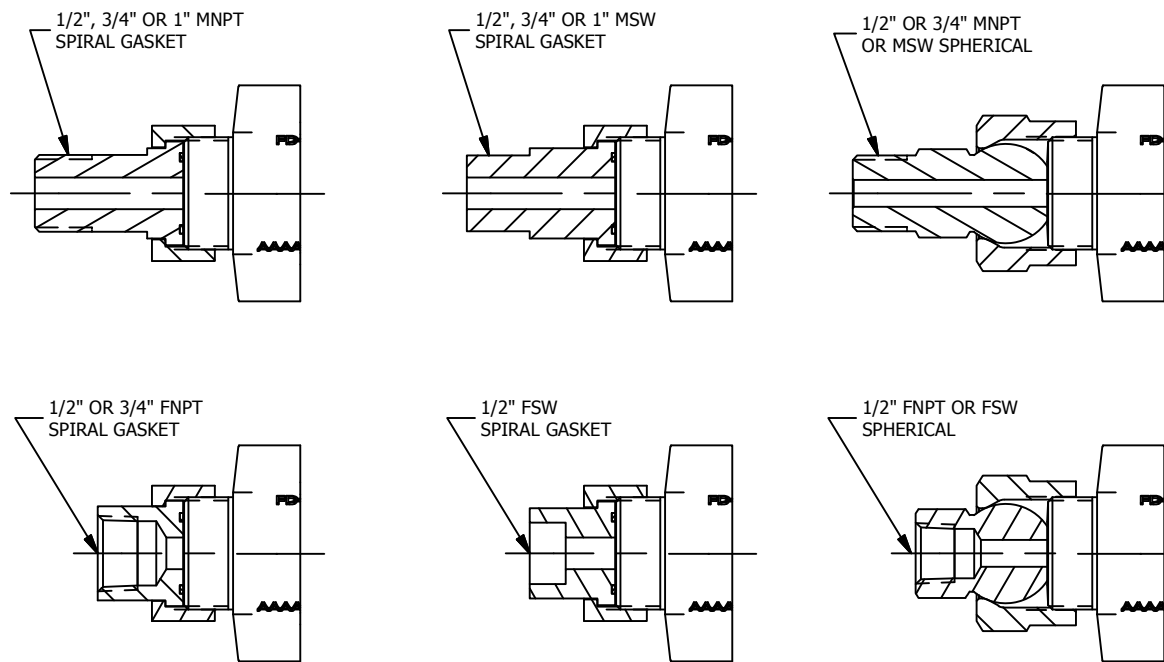

TANK & GAGE CONNECTIONS

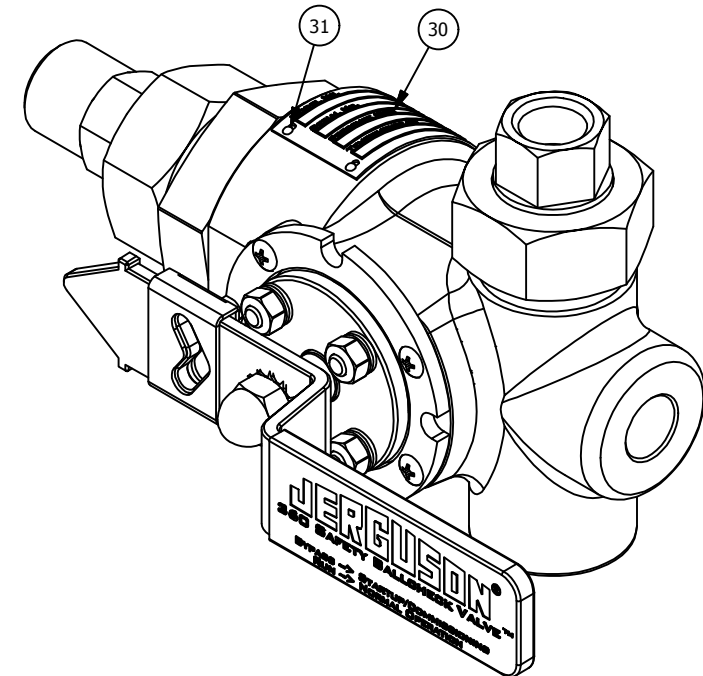
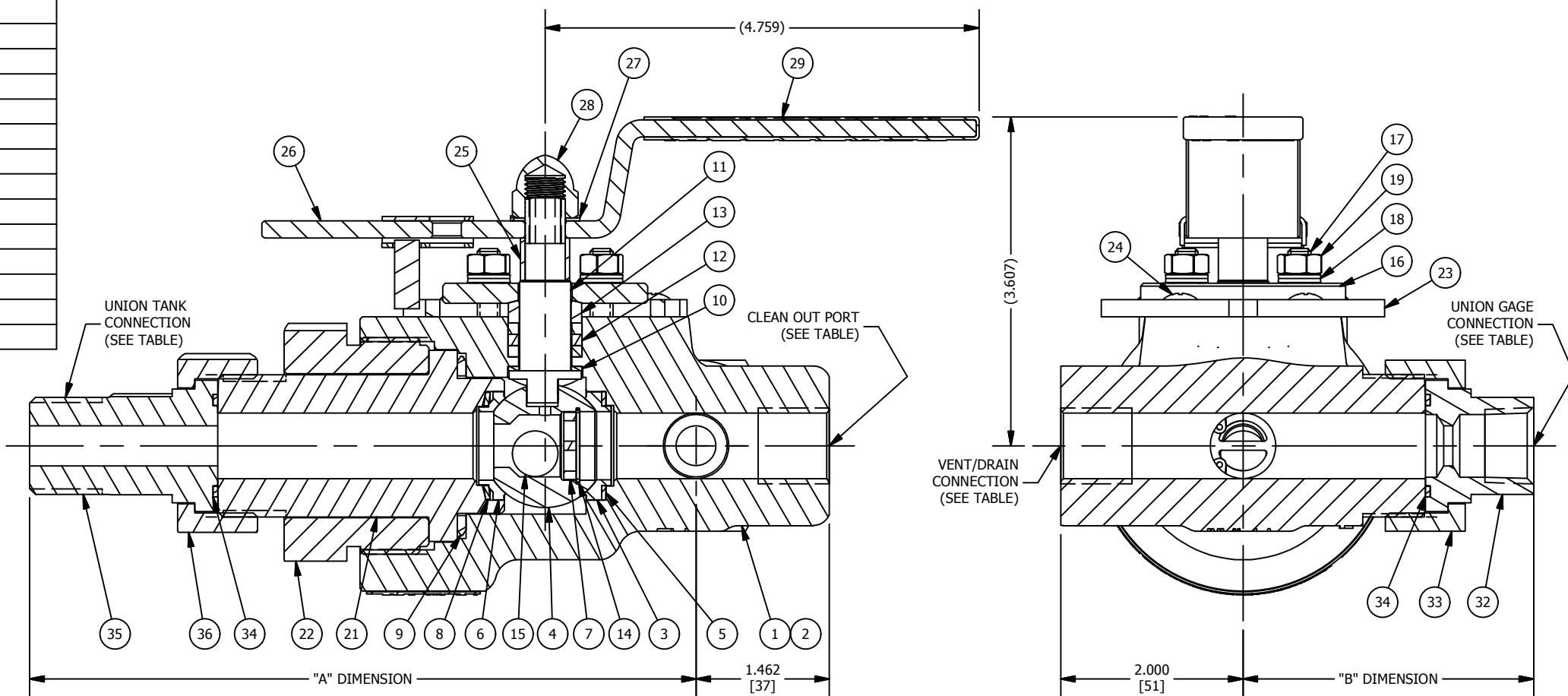

MANUFACTURED BY
Clark-Reliance®
16633 FOLTZ PARKWAY
STRONGSVILLE, OH 44149 USA
(440) 572-1500 | www.clarkreliance.com
© Clark-Reliance® Corporation. All Rights Reserved.

JERGUSON®
#364 SAFETY BALLCHECK VALVE
UNION TANK & GAGE CONNECTIONS

DRAWN: SH	REV.:
CHECKED: RMW	1
DATE: 7/18/2017	
REVISION: 1 PER CDC 17-347/SH 9/18/17	
DRAWING NO.: 364	