



BOILER WATER GAGES

Section: J100
 Bulletin: J100.60
 Date: 10/1/96
 Supercedes: P-A1

Specialists In Liquid Level Indication

For Pressures 250 to 750 W.S.P.

Gage and Valve Assemblies

Jerguson Gages and Valves are rugged, high-quality products constructed of the finest materials. They meet A.B.S. and U.S.C.G. regulations and A.S.M.E. Sec. I, code requirements for use on fired pressure vessels.

TUBULAR GAGE CLASSES... UP TO 250 W.S.P

Jerguson Tubular Gage assemblies represent years of experience in the manufacture of gage cocks for industrial steam services. The valves have union bonnets. Stems are quick closing and equipped with levers and equalizing plate for chain operation. Both stems have backseating knobs, seats are renewable and regrindable.

FLAT GLASS GAGES

Jerguson Gages for 300 W.S.P. thru 750 W.S.P. are available with the 10¼" or 12½" visible glass. Gages are equipped with polished end stems which fit into the outlet stuffing box connections of the valves. The stuffing boxes allow the end stems to slip slightly to allow for a differential in expansion rate between the drum and the gage assembly.

Numbers 103 and 123 gages are for the 300 W.S.P. and are available in both transparent and reflex design.

For working pressures over 300 W.S.P. the use of a mica shield between the glass and steam is recommended. Thus, the use of reflex gages is not recommended for higher pressures. Gages for pressures over 300 W.S.P. are offered in the transparent type only.

NUMBERS 107 AND 127 ARE FOR 750 W.S.P.

A mica shield protects the glass from the effects of high Ph and erosion caused by condensate rolling down the glass. Jerguson used only the highest quality mica with a minimum of vegetable stain and air inclusions to assure long life and good visibility.

All flat glass gages are constructed with chambers machined from solid bar stock carbon steel. Tempered glasses are manufactured under carefully controlled conditions which produce an exceptionally strong glass, resistant to both thermal and mechanical shock.

Units are assembled and maintained at the proper clamping load by special alloy steel bolts and nuts. Gage glasses rest on recessed gaskets between the chamber and cover.

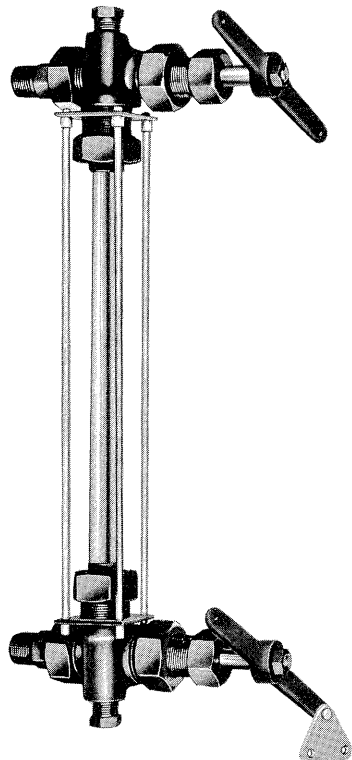

250 W.S.P.
No. 633-2

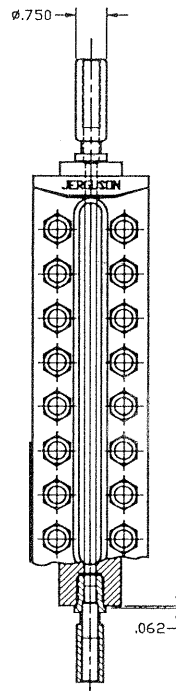

300 W.S.P.
103-123 Gage
Use 637-2 or 637-4 Valves

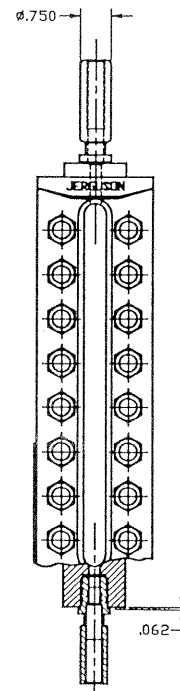

750 W.S.P.
107-127 Gage
Use 637 or 637-4 Valves

BOILER WATER GAGES 250-750 W.S.P.

VALVES

Shut off valve assemblies for the 250 through 750 W.S.P. have steel bodies with a union bonnet. The stem and renewable seat are of different hardness and analysis stainless steels prevent galling. The gland bears directly on the packing to prevent leakage around the stem. These valves are equipped with quick closing stems and levers for chain operation.

An equalizing plate on the bottom valve lever assures tight closing of both valves. The bottom valve is equipped with stainless steel ball check which shuts off the flow of water in the event of glass breakage or gasket failure. Inlet connections may be 3/4" male N.P.T. or ANSI flanged. The bottom valve has a 1/2" N.P.T. drain connection to which a 1/2" drain valve may be connected.

GAGE AND VALVE DIMENSIONS

	No.633-2	No.103	No.123	No.107	No.127
Visible Glass Length	CC-5 5/8"	10 1/4"	12 5/8"	10 1/4"	12 5/8"
Chamber Length	CC-2 3/8"	12 1/4"	14 5/8"	12 1/4"	14 5/8"
Min. Over-all Length	NOTE 1	17 3/8"	19 3/4"	17 3/8"	19 3/4"
Min. Center to Center	VG+5 5/8"	20 1/4"	22 5/8"	20 1/4"	22 5/8"

NOTE 1. Tubular gage glass can be furnished in length specified up to 24".

